

Wavelength Meter

WS6-600 IR-I Standalone



HighFinesse
The Standard of Accuracy



Ångström

Available Measurement Ranges

WS6-600 IR-I Standalone	630 – 1750 nm
-------------------------	---------------

Absolute (and Other) Accuracies

630 – 800 nm	600 MHz
800 – 1180 nm	500 MHz
1180 – 1750 nm	400 MHz
Quick coupling accuracy (with multi mode fiber)	600 MHz
Wavelength deviation sensitivity/Measurement resolution ²⁾	20 MHz
Linewidth estimation accuracy ³⁾	500 MHz

Measurement Speed

Continuous	1600 Hz
Trigger Mode 1	1400 Hz
Trigger Mode 2	800 Hz (with adjustable exposure time)

Required Input Energy and Power⁴⁾

IR-I	8 – 800 μ W
------	-----------------

For low power instruments with increased sensitivity, please contact HighFinesse support.

FSR of the Fizeau Interferometers (Fine/Wide Mode)

32 GHz/32 GHz

1) Using the built-in calibration source every week and an appropriate reference laser (e.g. HighFinesse SLR 1532) for calibration and lamp correlation every half a year.

2) Standard deviation.

3) Not better than 20 % of the linewidth.

4) The CW power interpretation in [μ W] compares to an exposure of 1 s.

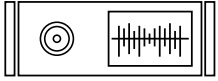

Wavelength Meter

WS6-600 IR-I
Standalone



HighFinesse
The Standard of Accuracy



Ångstrom

Calibration

Built-in calibration source, optionally an external laser can be used (e.g. HighFinesse SLR-1532)

Recommended calibration period \leq 1 month

Dimensions L \times W \times H

436 \times 342 \times 133 mm (without feet)

Weight

10.6 kg

Power Supply

50 W, external power supply included

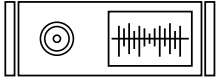

Wavelength Meter

WS6-600 IR-I
Standalone



HighFinesse
The Standard of Accuracy



Ångström

Interface

Standalone unit with touchscreen

Measurement data is processed internally

Network access via API:

control via HighFinesse network access shared library solution or Standard Commands for Programmable Instruments (SCPI)

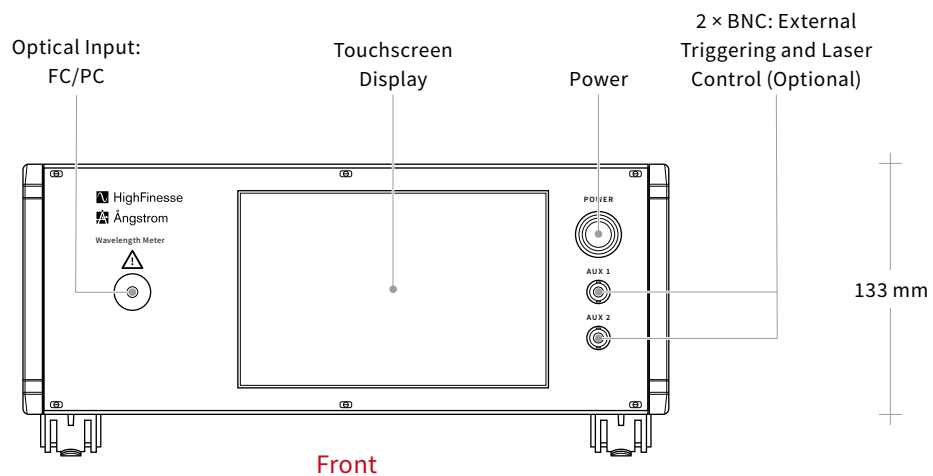

Front

342 mm

Back

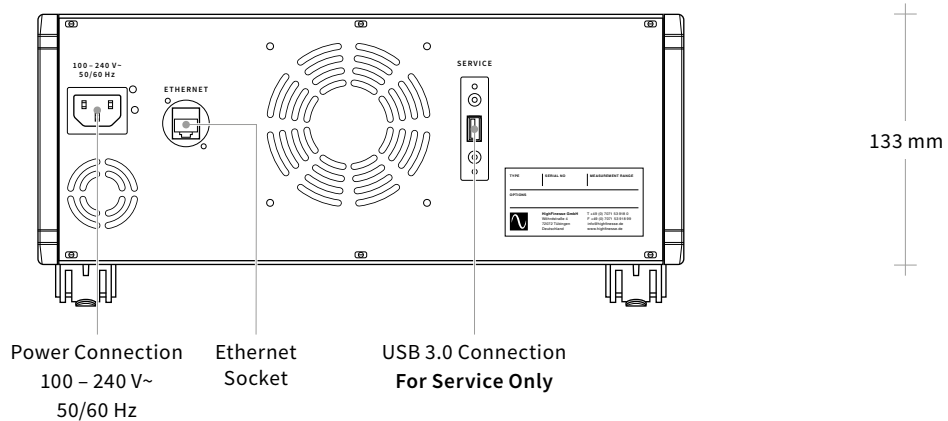

Power Connection
100 - 240 V~
50/60 Hz

Ethernet
Socket

USB 3.0 Connection
For Service Only

133 mm

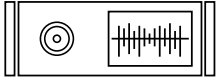

Wavelength Meter

WS6-600 IR-I
Standalone



HighFinesse
The Standard of Accuracy



Ångström

Options

External Trigger (TTL)

External triggering via TTL guarantees synchronization between pulsed excitation and measurement. It provides low-noise signals without parasitic parts when measuring pulsed signals with low duty cycles.

Laser Control (PID)

With the PID option it is possible to stabilize the frequency of a laser connected to the wavelength meter using a software based proportional-integral-derivative controller (PID controller). Unlike analog PID electronics, the PID option provides software based signal processing, allowing the laser to be stabilized to a specific user defined frequency or regulated with an arbitrary pattern.

This makes it extremely useful in experiments where the laser frequency has to be actively regulated or varied to fit changing experimental conditions, such as laser cooling, atomic detection, trapping and spectroscopy.

Linewidth Estimation (L)

The linewidth estimation of a singlemode laser source is performed by a special algorithm which eliminates the interferometer's instrument response function. The algorithm enables the estimation of the linewidth with an accuracy better than the tenth of the instrument FSR.

The linewidth option can also be used for measuring the linewidth of multimode lasers or lasers with sidebands. In this case, the longitudinal mode splitting needs to be less than the instrument's spectral resolution and the calculated result is the FWHM of the envelope function of the multiline spectrum. Any instrument can be upgraded with the L-option.

Singlemode fibers are required.

External Calibration (CAL)

The wavelength meter WS6-600 IR-I standalone features autocalibration via an integrated calibration source. This guarantees the accuracy and stability of measurements with our wavelength meter. For higher accuracy in the range from to we offer the SLR 1532.

For further information see our product description here: <https://www.highfinesse.de/cal>

Typical Applications

The WS6-600 IR-I Standalone offers an accuracy of 600 MHz. It is mostly used for pulsed lasers and cw laser. This instrument is best combined with singlemode fibers in order to reach optimum accuracy.

Further Information

For further technical information, application examples, diagrams and for customization of the WS6-600 IR-I Standalone please contact:

HighFinesse Team

service@highfinesse.de